

## DESIGN AND PACKAGING OF SENSOR SYSTEMS: A MULTIDISCIPLINARY PROJECT

Vukica Jovanovic<sup>1</sup>, and Andrea Mitofsky<sup>2</sup>

<sup>1</sup>Trine University, Angola, Indiana; Email: jovanovicv@trine.edu

<sup>2</sup>Trine University, Angola, Indiana; Email: mitofskya@trine.edu

### ABSTRACT

One collaborative student project, based on a multidisciplinary design approach will be shown in this paper. During the fall 2011 semester, electrical engineering and design engineering technology students at Trine University collaborated on a project to design and build hand held sensor systems and their packaging during the courses Subsystems and Design for Manufacture and Assembly. Electrical engineering students were required to build systems which included one sensor and an on/off switch. Additionally, students were given a maximum cost for the supplies, and all of the packages had to interconnect in some way. These students selected a sensor to use, designed a circuit which could display information from the sensor, and laid out the printed circuit board (PCB) for the device. After the initial PCB design was completed, electrical engineering students provided information about the PCB layout to technology students who started designing packages for the devices. After the PCBs were manufactured and all components were soldered, the final packaging was finalized and produced using a rapid prototyping machine. Students worked on multidisciplinary teams to complete the project. There were five groups of electrical engineering students, two or three to a group. Each group of electrical engineering students was paired with two groups of two or three technology students. This project required collaboration between students from different disciplines. Design technology students had various courses related to product design and some related to electrical fundamentals, but they have never worked on a product design project that involved electrical and electronic components which is something they will face in industry very often. Also, the electrical engineering students had to be concerned about issues like the placement of the sensor and switch, issues which are unimportant unless the circuit will be built. This project required a lot of design and decision making, yet the students needed to settle on a single design for their group. The resulting designs varied quite a bit from group to group, and students were proud of the designs that were built.

### 1. INTRODUCTION

During the fall 2011 semester, electrical engineering and design engineering technology (DET) students at Trine University collaborated on a project to design and build hand held sensor systems and their packaging during the electrical engineering course Subsystems and the DET course Design for Manufacture and Assembly. Engineers often work on teams with people from different disciplines, and the collaboration often occurs throughout the design process. The stereotypical engineer works alone designing a bridge, an amplifier, or a new engine while isolated from the rest of humanity. However, large-scale engineering work is rarely done in an

isolated manner (Rugarcia, *et al.*, 2000). A multidisciplinary approach which utilizes the ideas of concurrent engineering, where collaboration occurs throughout the design process, may increase the quality and capabilities of a finished product and decrease the time needed for development (Chen and Liang, 2000). According to a survey of industrial managers published in ASEE Prism (ASEE Prism, 1992), education of future engineers who will work in product design should include an emphasis on multidisciplinary projects and problem solving which teaches students to recognize the importance of teamwork as opposed to rivalry (Miller and Olds, 1994).

Multidisciplinary projects require a range of skills which students are not always introduced to in a typical lecture class. Product design in a multidisciplinary environment is a knowledge intensive activity in which collaborators must be able to exchange information and share some mutual understanding of the information content (Olsen, *et al.*, 1995). Very often, so called “soft skills”, such as listening, understanding others’ viewpoints, leading without dominating, delegating and accepting responsibility, and dealing with the interpersonal conflicts that inevitably arise, may be more crucial to the success of a project than technical expertise (Rugarcia, *et al.*, 2000). Therefore, effective communication and coordination are vital to collaborative product development (McGuire, *et al.*, 1993; Fruchter, 1996). Moreover, due to recent changes in information technology, engineers are expected to be familiar with multiple ways of communicating and collaborating with other engineers.

## 2. PROJECT REQUIREMENTS

Electrical engineering students were required to design a sensor system which contained one, and only one, sensor and an on/off switch. They were required to select the components, design the circuit, and layout the printed circuit board (PCB). The PCBs were manufactured externally by ExpressPCB (ExpressPCB website, 2012), and then the students had to solder the components on the PCB. They had the freedom to choose any components that they wanted as long as the cost of components, not including the PCB, was less than \$20 per board. A suggested list of 20 components, which were in stock in the electrical engineering department at the time and which included sensors, switches, opamps, and LCD displays, was provided to the students to help them begin their designs. Additionally, the designs were required to fit onto a 3.8x2.5” PCB. Electrical engineering students were required to document their design process using both a journal and a final report. Final reports needed to include a complete parts list, circuit diagram, printout of the PCB layout, and a user's guide for their device.

Each group of DET students had to design a package for one of the different sensor systems the electrical engineering students made. Each package was required to interconnect with the other packages to form a single assembly. Students had to design packaging that would have easy access to the switch and sensor as well as allow for battery replacement. The PCB and batteries needed to attach to the package safely and securely. Students were required lay out their designs using SolidWorks, and the packages were printed on a rapid prototyping machine. Students worked on teams to complete the project. There were five groups of electrical engineering students, two or three to a group. Each group of electrical engineering students was paired with two groups of two or three technology students due to the fact that the DET class was larger than the electrical engineering class. In DET groups, usually one person was responsible for 3D modelling, one person was responsible for prototyping, and a third person was responsible for

taking accurate measurements and keeping the project on track. Students were paired up with their team members at the beginning of the semester, and they collaborated through email and face-to-face meetings. In an attempt to spot possible design problems early, the students were encouraged to talk to their teammates often and use ideas of concurrent design. For example electrical engineering and DET students were required to meet after the PCBs were laid out but before they were ordered because errors could be fixed more easily before the PCBs were printed.

### 3. PROJECT DETAILS AND EXAMPLE SOLUTIONS

#### 3.1. Circuit Design and Prototyping Project Details

Students began the circuit design process by selecting then testing their sensor and the display separately. Next, a prototype of the entire sensor system was built on a protoboard to allow for easy debugging, alteration, and refinement. Some, but not all, groups used a circuit simulator at this point to aid in their design process. The next step was to layout the PCB. The final step for the electrical engineering students was to solder components on their finished PCB. Since the projects was quite open ended, the resulting sensor systems were each unique. Two groups of students choose microphones as their sensor, one group used a force sensor, one group used a temperature sensor, and one group used a Hall Effect sensor which measures magnetic field. Three of the groups used LCD displays which were driven by combined analog to digital converters and display drivers. The remaining two groups used discrete LEDs to display the output. Three groups used 9V batteries while two groups used AA batteries. The sensors, LCDs, and LCD drivers used are detailed in the table below which shows part numbers and costs from Digikey (Digikey website, 2012).

Table 1: Part numbers and costs (Digikey website, 2012).

Description	Part Number	Cost
Microphone	CMA-4544PF-W	\$0.96
Force Sensor	30-49649	\$6.80
Thermistor	NTCLE100E3333JB0	\$0.35
Hall Effect Sensor	A1302KUA-T	\$1.54
LCD Display	VI-301-DP-RC-S	\$3.22
LCD Display	LCD-S2X1C50TR	\$3.01
Display Driver	ICL7106CPLZ	\$4.23

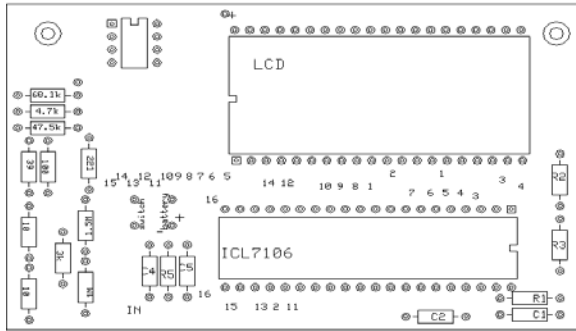

a) PCB layout for force sensor

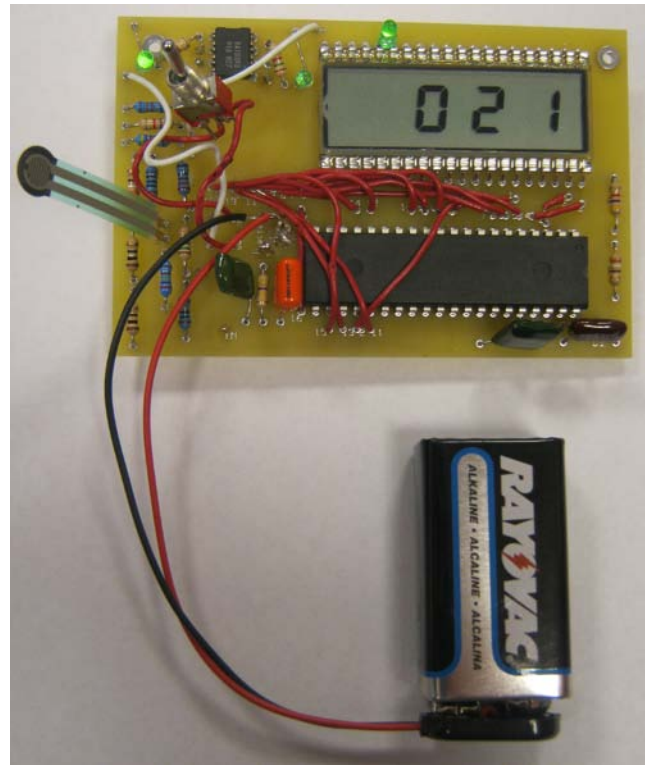

b) Soldered PCB for force sensor

Figure 1: Example of one PCB board layout and prototype for force sensor

PCBs were manufactured by ExpressPCB (ExpressPCB website, 2012). The PCBs were laid out using software provided by ExpressPCB and available free online. The students had not used the software before, and they were not provided any formal instruction on how to use it. However, following tutorials provided with the software, they were all able to learn it quickly and use it successfully for this project. To keep the cost of the PCBs down, students were required to use only one layer of copper in their designs. If a wire crossing was needed, a jumper wire was soldered into place. The simplest design required only one jumper wire while the most complicated design required more than a dozen jumper wires. Figure 1 shows an example PCB layout and a photograph of the soldered PCB.

### 3.2. Packaging Design and Prototyping Project Details

Students began the packaging design by carefully measuring the dimensions of the batteries, displays, and other components of the PCBs. They came up with a design envelope using SolidWorks. Next, they incorporated information about their specific PCB into the design envelope. This step involved creating a stand to hold the PCB as well as a compartment or box to hold the batteries. Finally, the finished designs were manufactured using a rapid prototyping machine.

In the initial stage of the design, students proposed design envelopes which could contain the PCBs and interconnect in some way. One student came up with a design envelope which had a separate top and bottom piece that fit together with a tongue and groove design. The word 'bottom' was engraved on the bottom piece so that all designs would be oriented correctly. Some systems had displays, so it was important to orient them in the same way. Furthermore, the design had dovetail-like slots on four sides so the assemblies could interconnect. This design envelope was selected and used as a starting point for further design by all groups. Figures 2 and 3 illustrate this design envelope and how the packages interconnect.



Figure 2: Design envelope assembly

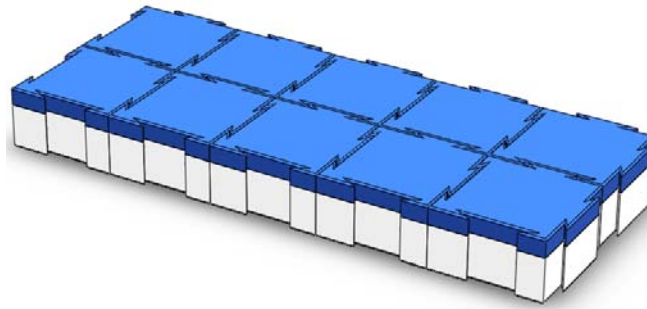
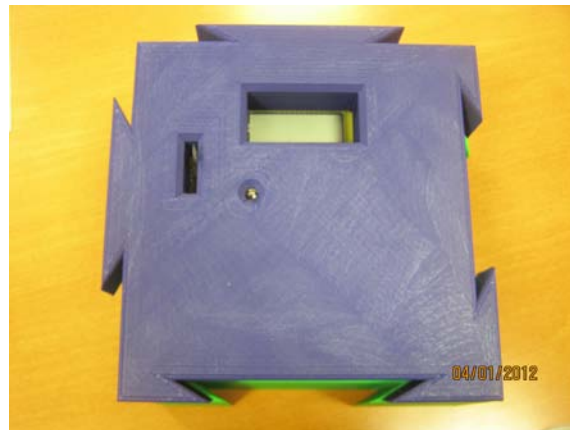

Figure 3: Proposed solution for interconnectivity



a) Force sensor base



b) Force sensor packaging

Figure 4: Example of PCB packaging – force sensor

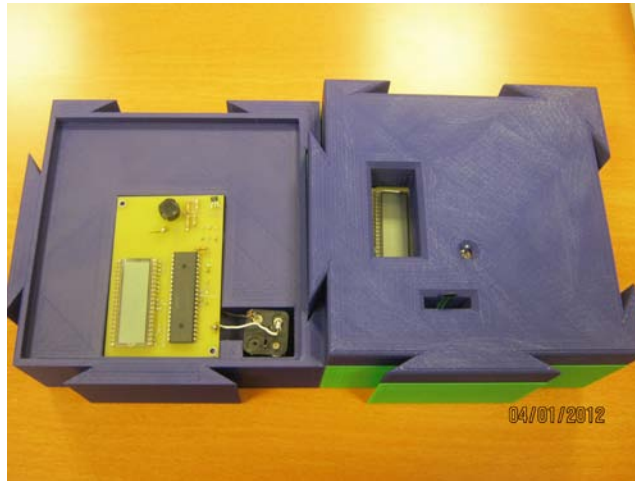

Figure 5: Example of two PCB packaging solutions

Next, students edited the design envelope to fit their specific sensor system. This step involved taking into consideration factors such as the size of the batteries, the placement of the sensor and display, and the location of mounting holes on the PCB. The PCB layouts were saved in the neutral exchange file type DFX and imported into SolidWorks to aid in the design process. Students had to make sure that the packages left enough room for wiring, and they had to make sure that the PCBs would fit into the package. Additionally, they had to make sure that the batteries would be stably secured and that the batteries could be easily replaced if needed.

Once the package designs were finished, they were saved as STL files and sent to a rapid prototyping machine available at the university. The packages were constructed using ABS plastic. The bottom of each package required approximately 16 hours to construct, and the top required approximately 14 hours. However, with further improvement to the design, the packages could be made smaller and could require considerably less time to manufacture.

#### 4. LESSONS LEARNED FROM THE PROJECT

##### *4.1. Circuit Design and Prototyping Lessons Learned*

Electrical engineering classes often focus on analysing information contained in circuit diagrams. In this project, the electrical engineering students had to design their own circuit diagram, but they also had many decisions to make that did not show up on the circuit diagram. The students had to be concerned about issues like the thickness of wires, the spacing of the holes on the PCB, the number of wire crossings, and the vertical height of components from the surface of the PCB. These issues are all important and all related to design of circuits, but they go beyond issues discussed in a typical circuits or electronics course.

Since the project was quite unstructured, students could decide on how complex to make their design. Some groups chose to add multiple features including LED indicators for power and low battery. However, groups with more complicated designs ran into more issues when laying out their PCB. Some designs required over a dozen jumper wires on their PCB because one layer of

copper was not enough to interconnect all of the components. Also for the more complicated designs, the components on the PCB needed to be placed so close together that soldering became more challenging. Also, only the simplest PCB came back without any errors in need of correcting.

Students were encouraged to use discrete electrical components, such as opamps and A/D converters. Three groups of students used a combination A/D converter and LCD driver which had 40 pins. Wiring this chip proved complicated but possible. At the end of the project, some students felt that it would have been easier to design the circuit using a microcontroller instead, and the wiring of the microcontroller would have been no more complicated than the designs they came up with.

#### *4.2. Packaging Design and Prototyping Lessons Learned*

The first lesson learned was that a project like this is very beneficial to DET students. DET students learned a lot from this kind of collaboration with EE students since they have never had a project like this before. Design engineering classes often focus on information contained in a computer aided design (CAD) drawing. In this project, the DET students had to worry about many additional issues not obvious from a CAD drawing. They had to ensure that their packages left enough room for wiring. Also, they had to design a way for the user to open the package to change the batteries. Additionally, they had to ensure that the switch and sensor were placed in convenient locations so the device could be used easily. The DET students had various courses related to product design and some related to electrical fundamentals, but they have never worked on a product design project that included electrical and electronic components which is something they will face in industry quite often.

The second lesson learned from the classroom team management perspective is to make sure that all team members are equally involved during the design stage in future. Students had various comments related to their contribution and influence on the final design solution. One student came up with the design envelope which was used by all of the groups. For this reason, some students felt that their creativity was taken away and too much of the package design was completed for them. Some students valued the modelling work more than the collaboration or design work. They felt that the student who did the most 3D modelling contributed most to the project. If they were not involved in the modelling, they did not feel a strong sense of accomplishment regardless of their involvement in the collaboration, brainstorming, or other activities related to the project.

The third lesson learned is to enable more space for changes later in the project so that students could come up with new design solutions after they fully understand the design purpose. Early in the design process, all groups decided to use the same design envelope, but by the end of the semester, many students had ideas for how to improve the design envelope. More specifically, after the PCBs were received, they realized the package was too large. The size of the design envelope was based on the maximum dimensions of the electrical components reported by the groups. If time allowed, this problem could have been solved with an iterative design procedure. Some groups said that they could have made their packaging fifty percent smaller than it was if the design envelope was not influencing their designs.

The fourth lesson learned was the importance of early communication between DET and electrical engineering students. Some groups put off working on the package design until the PCBs were assembled. Since DET students had never worked on a project like this, they did not know exactly what the finished PCBs would look like and which parameters of the boards would be important. Once the PCBs were actually made and soldered, they had more ideas for their designs. However, the PCBs could not easily be altered at this point. Some groups did not carefully consider the size of holes used for assembly. Also, some groups did not carefully consider which side of the PCB certain components were located on which made packaging designs more challenging. Before the PCBs were finished, some DET students thought that the package designs could be finished quite quickly, in less than a week. However, once they received the finished PCBs, they realized that the project was quite involved, and they thought their designs could be much better if they had more time to refine their packages.

#### *4.3. Teamwork and Lessons Learned*

The first lesson learned related to teamwork was the importance of scheduling classes at the same time to facilitate face-to-face meetings. This project required that students from different majors work together. Coordination was complicated by the fact that the electrical engineering and DET classes met at different times. A significant amount of time was devoted to the project in both classes. However, unless a student was free at the time of the other class, meetings outside of class were required. Students occasionally complained that their teammates were hard to contact and did not reply to original requests to meet. However, with persistence, they were all able to arrange times to discuss the project. Since the project was a challenge with class time available, it would have been much harder without the class time available. In future, this could be avoided if these two classes would be scheduled at the same time.

The second lesson learned was related to different sizes of the classes. Additionally, coordination was complicated by the fact that each group of electrical engineering students was paired with two groups of DET students. This arrangement was necessary because the DET class had more than twice the number of students as the electrical engineering class. Some DET students mentioned that contacting the electrical engineers was complicated by the fact that the electrical engineers had to split their time between two groups. The DET class was classroom-based while the electrical engineering class was project-based. More even involvement in the project would have been possible if the classes involved were both project-based or both classroom-based with almost equal number of student. However, this class scheduling arrangement is hard to achieve.

The third lesson learned also was related to course schedule. Some students commented that their package designs would have been smaller and required less time and material to construct if the packages did not have to interconnect. However, one of the main ideas of the interconnectivity was to encourage collaboration between the groups. This problem could have been avoided by splitting the project into two design stages. In the initial stage, electrical engineering and DET students would collaborate and brainstorm possible solutions. In the final stage, after the PCB boards were manufactured, the DET students could finalize their designs for a specific sensor system.



## 5. CONCLUSIONS

Overall the project was a success. Students designed all aspects of the sensor circuit. The printed circuit boards were manufactured professionally. Then, the students soldered the components on the boards and designed and manufactured the packages. The resulting designs varied quite a bit from group to group, and students were proud of their designs. At the end of the project, both DET and electrical engineering students had many ideas for possible design improvements. Also at the end of the project, they had a greater understanding of what it takes to manufacture a product, and they had a greater appreciation for the work done by engineers in the other discipline. The next time this project is run, it would be beneficial to develop assessment tools for use at the beginning and end of the semester. The tool at the beginning of the semester could measure the amount of knowledge students have about multidisciplinary design methods and problems that could arise in multidisciplinary design. The tool at the end of the semester could measure how their knowledge of multidisciplinary work evolved over the semester. Additionally, the assessment tool at the end of the semester could measure how much DET students learned about PCB design and manufacture how much the electrical engineering students learned about package design and rapid prototyping.

## ACKNOWLEDGEMENTS

Sam Swerdlow and Josh Hedger designed the electrical circuit of the sensor system shown in Figures 1 and 4. Daniel Grabill designed the design envelope that was used in this project with dovetail slots shown in Figures 2 and 3. Nicholas Cocanower, Lukas Garrow and Cody Nash-Kniffen designed and manufactured packaging shown in Figure 4 and Figure 5 on the right. Jordan Troxel, Preston Moudy and Morgin Stell designed the packaging shown in Figure 5 on the left. We would like to acknowledge their hard work on this project and thank them for allowing the use of the images.

## REFERENCES

- American Society for Engineering Education Prism* (1992). "Real World 101: What Some Engineers in Industry Want Your Students, and You, to Know," October, pp. 19-22.
- Chen, Y.M., and Liang, M. W. (2000). Design and implementation of a collaborative engineering information system for allied concurrent engineering, *International Journal of Computer Integrated Manufacturing*, 13 (1), p11.
- Digikey website, <http://www.digikey.com>, date accessed 1-1-12.
- ExpressPCB website, <http://www.expresspcb.com>, date accessed 1-1-12.
- Fruchter, R. (1996) Conceptual, Collaborative Building Design through Shared Graphics, *Journal IEEE Expert: Intelligent Systems and Their Applications archive*, IEEE Educational Activities Department, 11 (3), June, p 33 – 41.
- McGuire, J.G., Kuokka, D. R., Weber, J. C., Tenenbaum, J. M., Gruber, T. R., and Olsen G. R. (1993). SHADE: Technology for Knowledge-based Collaborative Engineering, *Concurrent Engineering* September, 1 (3), p 137.
- Miller, R. L., and Olds, B. M. (1994). A Model Curriculum for a Capstone Course in Multidisciplinary Engineering Design, *Journal of Engineering Education*, October, p. 1.

Olsen G. R., Cutkosky M., Tenenbaum J. M., and Gruber T. R. (1995). Collaborative Engineering Based on Knowledge Sharing Agreements, *Concurrent Engineering*, June, 3 (2), p 145.

Rugarcia, A., Felder, R. M., Woods, D. R, and Stice, J. E. (2000). A Vision for a New Century, *Chemical Engineering Education*, 34(1), 16-25, p.9.